

LWIR Continuous zoom – commercial off the shelf lens

PECAN

24 – 105 mm F/1.55 LWIR Continuous zoom Lens

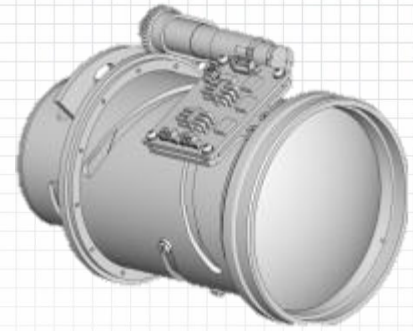

FEATURES / APPLICATIONS / CAPABILITIES

- Suitable for various applications
- Cost effective solution for HLS
- Rugged design for harsh environments

PARAMETER		VALUE	NOTES
Main	Sub		
🕒 OPTICAL			
Focal Length / F#		24 - 105mm / F1.55	Nominal values
Detector (FPA) type / size		640 x 480 x 17 μ	Effective detector size of 10.88 x 8.16 mm
FOV (degrees)		Wide: 26°(H) x 19.5° (V) Narrow: 5.95° (H) x 4.45° (V)	640 x 480 x 17 μ
Optical Coatings			
	All internal surfaces	High efficiency AR coating	Average transmission of entire lens with HD: 87%
	Front surface	High durability AR coating	DLC is available upon request: Average transmission of entire lens with DLC: 81%
Optical Total lens track		130 mm	Nominal from 1 st surface vertex to detector FPA
⚙️ MECHANICAL			
Mechanical Back Focal Length		9 mm	Nominal
Zoom mechanism/ Focus		Motorized	5m – Infinity for Wide 10m – Infinity for Narrow
Thru zoom boresight			Better than 0.15 mm
NFOV boresight retention			Better than 0.045 mm
Total Weight		875 grams	Nominal
Ext. Dimen \varnothing x length (mm)		95 x 119 (Please refer to MICD)	
💡 ELECTRICAL			
Power Input		12VDC, 1.0A	Nominal
Communication Protocol		RS-422/232 Full Duplex	Baud rate 19,200, n, 8, 1
🌿 ENVIRONMENTAL			
Operating/Storage Temperature		-20°C to +60°C / -40°C to +80°C	
Shock and Vibrations		Per applicable standard	
Front lens sealing		IP67	For front element only